

MWD-QDT(150°C) Battery Pack Specifications

1. Product Category and Model

1.1 Category:

High temperature type--sub-high temperature lithium-thionyl chloride battery pack

1.2 Product Model:

MWD--QDT (150°C) 29.2V battery pack

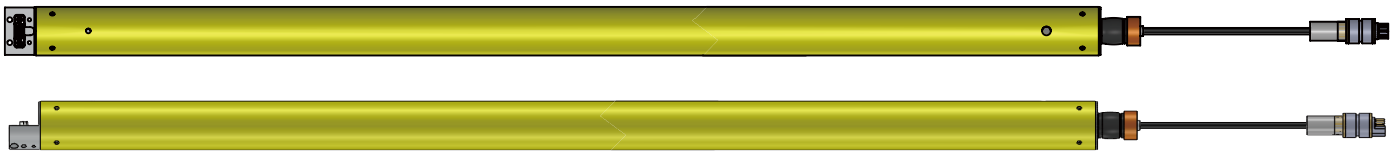

2. Battery pack characteristics

No.	Project	Characteristic	Remark
1	Model	MWD-QDT (150°C)	
2	Nominal Voltage	29.2V	
3	Load Voltage	≥27.5V	750mA
4	Standard Discharge Current	400mA	
5	Nominal Capacity	28Ah	
6	Working Temperature	-20°C-150°C	Please contact the manufacturer for operating temperatures below -20°C or above 150°C
7	Maximum Dimensions/mm	φ37.5x1184	Not including leads (lead length 260mm)
8	Maximum Continuous Discharge Current	800mA	(120°C - 150°C environment)
9	Maximum Pulse Discharge Current	1400mA	(120°C - 150°C environment)
10	Weight	2.75kg	
11	Battery Pack Safety	Full diode insurance. Protection	Total Insurance: 5A Single battery: 7A

3. Structure and Appearance

3.1 Battery pack structure:

Main materials of the battery pack: ER321270S (150°C) lithium battery, aluminum alloy tube or composite glass fiber tube, Teflon silver-plated wire, HL1910 circular special connector.

3.1.1 Basic performance of single ER321270S (150°C) lithium battery:

ER321270S-150

3.6V Li/SOCL2 System Battery
Size DD, Winding Structure Battery

ADVANTAGES:

- ◆ Stablehigh VOP and Capacitance
- ◆ High Energy Density and Stable Current
- ◆ Wide working tempraturerange (-40°C~+150°C)
- ◆ Lower Self discharge rate (EVG annual rate below under +20°C surroundings)
- ◆ Excellent environment application features
- ◆ Stainless steel shells (Low magnetism and environment erosion resistance)

FEATURES:

- ◆ Stainless steel-Glass hermetic package
- ◆ Non combustible electrolyte
- ◆ High short circuit safety
- ◆ Meet the technical requirements of IEC60088.4:2014
- ◆ Passed UL component testing certification (MH45919)
- ◆ Comply with RoHS environmental requirements, easy to be recycled.

MAIN APPLICATION:

- ◆ Utility Meters
- ◆ Alarms and Safety Equipments
- ◆ Memory Storage Backup Devices
- ◆ RFID
- ◆ Automotive Electronics
- ◆ Real Time Clocks
- ◆ Marine Surveying Equipments
- ◆ Oil Production Equipment

WARNING:

Do not charge,short circuit,heat over 150°C , breakdown, put into water, or weld directly on the surface of the shells. If you do like that,explosion, burning or Acid leakage inside the battery will be caused.



ELECTRICAL PERFORMANCE

(Typical data from those being stored for or within 12 months under 25 ± 15°C surroundings)

Nominal Capacity: **28Ah**

(The capacity is tested under the condition of 200mA +25°C and cutoff voltage 2.0V. Battery capacity will change with the change of discharge current, ambient temperature and cutoff voltage.)

Open Circuit Voltage (Typical data at+25°C) : **3.67V**

Nominal Voltage (at +25°C with load 0.6mA) : **3.60V**

Max. Continuous Discharge Current: **1000mA**

(If you need higher current that of 50% normal capacity at +25°C and 2.0V cut-off voltage; pls contact GMB)

Max. Pulse Capacity Current: **1500mA**

(At+25°C, An unused battery begin to discharge with 10 μ A base current, and during the process, a pulse of 1500mA0.1s will be discharged every two minutes,when the voltage reading will be higher than 3.0V. The voltage reading will change with the change of the pulse characters temperatures and storage conditions. If under hard conditions, we suggest using LICC or SC together with batteries. Details pls contact GMB.)

Storage (Suggestion) : **+30°C at most**

(If you have higher requirements or harsh terms, pls contact GMB)

Operating Temperature Range: **-40°C ~ +150°C**

(If exceeded, capacity will decrease, voltage reading be too lower and Initial pulse voltage reading be relatively low.)

PHYSICAL PERFORMANCE

Diameter (Max): **34.5mm**

Height (Max): **124.5mm**

Typical Weight: **208g**

Lithium Metal Content: **7.3g**

ER321270S-150

3.6V Li/SOCL2 System Battery
Size DD, Winding Structure Battery

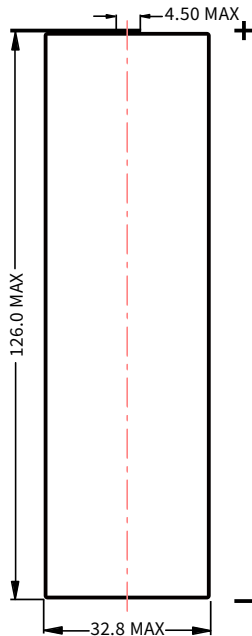

Size unit :mm (GB1804-m if tolerance is not specified) For special connection requests, please consult GMB

MAIN APPLICATION:

- ◆ do not short out the battery
- ◆ do not charge the battery
- ◆ do not pin the batter
- ◆ do not squeeze the battery
- ◆ pay attention to the battery anode and cathode
- ◆ electrical equipment connection is correct
- ◆ do not disassemble the battery
- ◆ do not burn batteries
- ◆ do not mix old and new batteries
- ◆ do not heat the battery to more than 150°C
- ◆ do not directly weld the battery
- ◆ please use a battery with pre-welded pins or wires.

NOTICE:

GMB reserves the right to change the information contained in this data sheet without prionnotice. Any performance parameters mentioned in this file arefor reference only, and the contents of this document can be used as valid contract data only after written confirmation by both parties.

1. Voltage VS Capacity at +135°C (intermediate value)

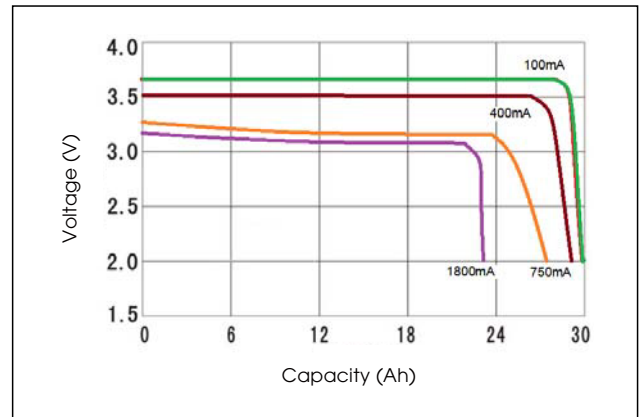

2. Current VS Temperature

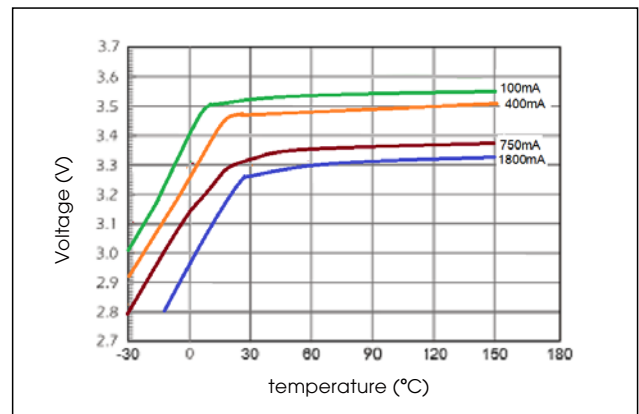

3. Capacity VS Temperature (cut off at 2.0V)

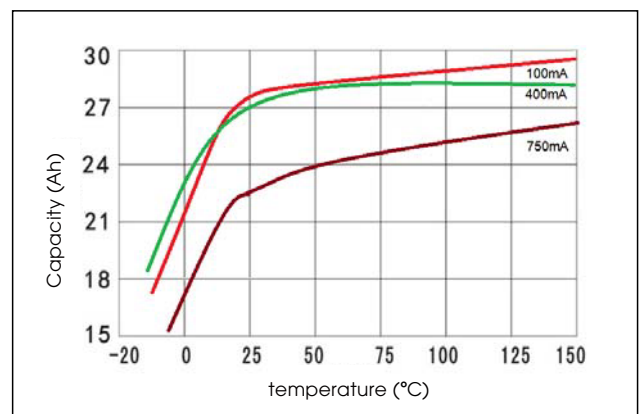

3.1.2 Capacitor discharge test:

3.1.2.1 Rated capacity test:

Put the battery in a test environment of 150°C for 12 hours, discharge it with a standard discharge current of 200mA constant current to a cut-off voltage of 2.0V, or connect a 17200mΩ load and discharge continuously until the battery voltage reaches a cut-off voltage of 2.0V.

3.1.2.2 Rapid discharge capacity test:

Put the battery in a test environment at 150°C for 12 hours, discharge it with a constant current of 1200mA to a cut-off voltage of 2.0V, or connect a 2900mΩ load and discharge continuously until the battery voltage reaches a cut-off voltage of 2.0V.

3.1.2.3 Storage and capacity:

After the battery is stored at 60°C for 28 days, it is placed in a dry place at 25 ± 5°C for 4 hours, and the discharge capacity test is carried out according to the rated capacity test method in 3.1.2.1.

3.1.3 Seismic performance:

Vibrate the battery with a simple harmonic vibration with an amplitude of 0.8 mm (maximum double amplitude of 1.6 mm). The initial vibration frequency is 15Hz-1000Hz-15Hz, the reciprocating time is 60m, the acceleration is 200m/s², and the vibration is one cycle.

3.1.4 Quality Consistency Inspection:

The quality consistency inspection is used to judge whether the battery is qualified in the production process and to ensure the stability of product quality. Can refer to GB/T8897.1-2013, GB8897.2-2013 standard implementation.

3.2 Characteristics of HL1910 circular special connector

3.2.1 Conditions of use:

Operating temperature	Working Pressure	Relative Humidity	Vibration	Impulse
-40°C-125°C	0.1Mpa-80Mpa	90-95% at 40°C ± 2°C humidity	10-1000Hz acceleration 196m/s ²	480m/s ²
150°C for a short time	Short time 100Mpa			

3.2.2 Main technical indicators:

Working Current	Contact Resistance	Insulation Resistance	Dielectric Strength	Life
5A	≤ 10mΩ	normal atmospheric conditions ≥ 1000mΩ, high temperature environment ≥ 200mΩ, after humidity test ≥ 10mΩ	Voltage 500Vac after 250Vac test	1000 times

3.2.3 Structure diagram of HL1910 circular special connector:

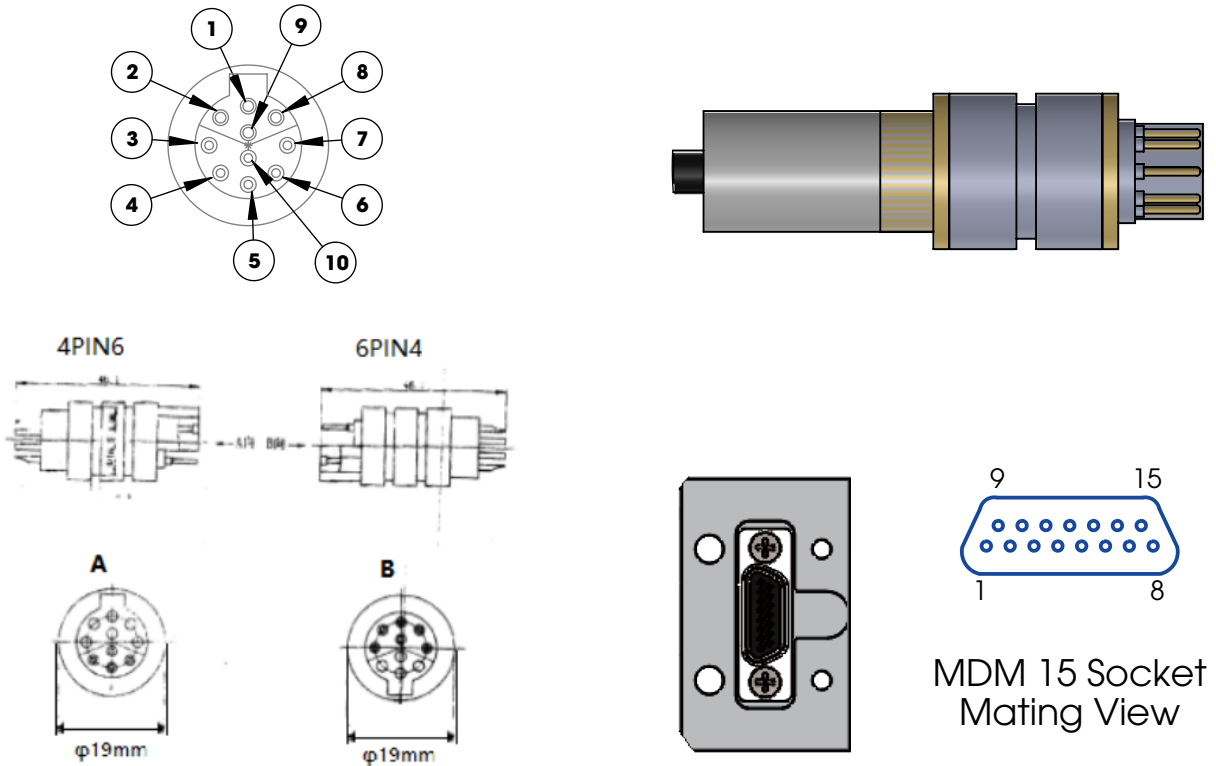

3.3 Basic dimensions and structure diagram of the battery pack:

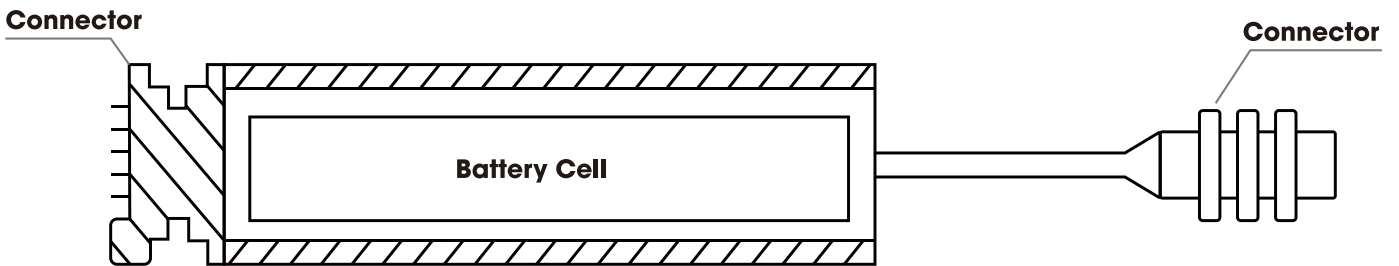

3.4 Basic electrical diagram of battery pack:

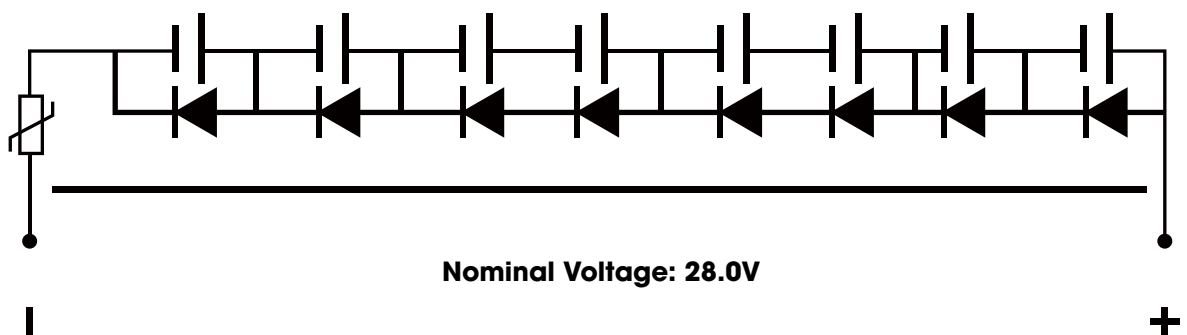

3.5 Communication Connection Diagram of Battery Pack Connector:

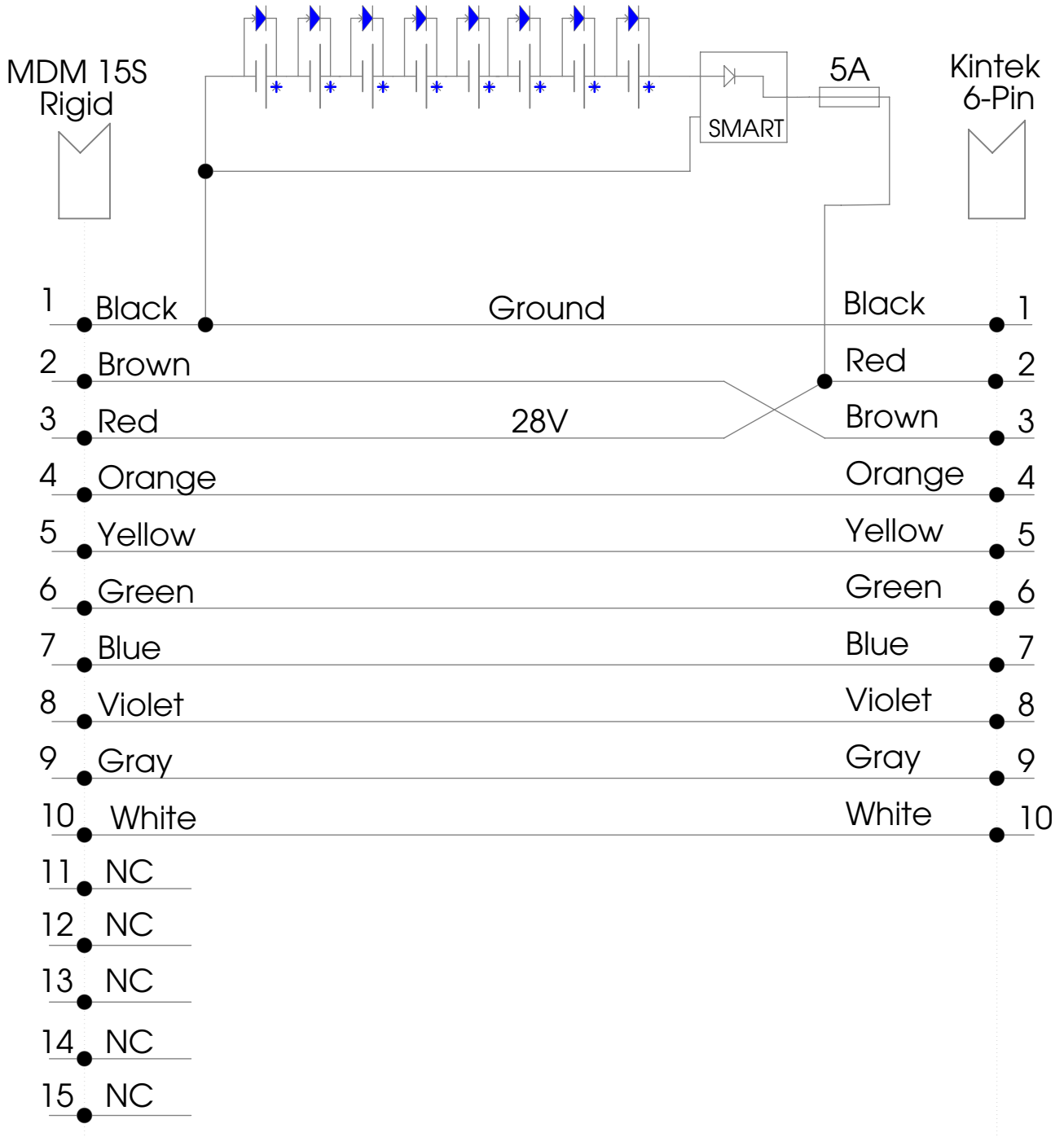

4. Security features

No.	Project	Judgement Standard	Test Methods
1	Seismic performance	No explosion, no fire, no leakage	
2	Leakproof performance	No explosion, no fire, no leakage	
3	Insulation properties	No explosion, no fire, no leakage	
4	Continuity test	smooth communication	



5. Test

5.1 Test conditions and instruments:

5.1.1 Standard test environment:

Unless otherwise specified, the standard conditions for detection are:

Temperature: 120°C-150°C, relative humidity: $40 \pm 5\%$, atmospheric pressure: $90 \pm 10\text{Kpa}$

5.1.2 Test time:

Testing should be done within one month of delivery.

5.1.3 Measuring instruments:

(1) The voltage measurement is carried out with a voltage with an accuracy of not less than 0.5, an accuracy of 0.01V, and an internal resistance of 10M Ω or more.

(2) The length of the battery pack shall be measured with a meter ruler with an accuracy of no less than 1mm, and the diameter shall be measured with a vernier caliper with an accuracy of no less than 0.02mm.

5.2 Test method:

5.2.1 Open circuit voltage:

Store the battery pack sample in the standard environment of 5.1.1, and then use the voltmeter specified in 5.1.3 (1) to measure the voltage between the positive and negative electrodes of the battery pack at the same temperature. The voltage value should be 28.5-29V. (Any short circuit will cause the open circuit voltage of the battery to drop or cause the total fuse of the battery pack to break, resulting in no voltage)

5.2.2 Load voltage:

Place the battery pack in the standard environment of 5.1.1 for 30 minutes, discharge it with a load of 200mA for 5 minutes, and measure the voltage between the two poles of the battery with the voltage specified in 5.1.3 (1). The voltage is not lower than 20V.

NOTE: If you do not plan to use the new battery immediately, do not load it, because loading will cause the battery to discharge, thereby reducing the life of the battery.

5.2.4 Leakage performance:

Vibrate the battery, the initial vibration frequency is 10Hz-1000Hz-10Hz, the reciprocating time is 60min, the acceleration is 196m/s², and the vibration is 1 cycle.

5.2.5 Insulation properties:

Use a 20M Ω multimeter to point the 1-10 pins of the battery pack connector and the outer wall of the battery pack, point the black pen on the 1 pin of the connector, and point 2, 3, 4, 5, 6, 7, 8, 9, 10 with the red pen to the outer wall. And so on black pen to the outer wall. Between the needles and the outer wall $\geq 20\text{M}\Omega$.

5.2.6 Continuity test:

1. Connect the component detectors to both ends of the battery cartridge, and set the switches to the "off" position;

2. Put the multimeter on the bell ohm range, measure the resistance between the "lower 1" and "upper 1" sockets, the reading value should be less than 1 ohm, and you can hear the beep;

3. Measure "upper 2" and "lower 2", then "upper 3" and "lower 3", "upper 4" and "lower 4", "upper 5" and "lower 5", "upper 6" and "lower 6", "upper 7" and "lower 7", "upper 8" and "lower 8" should be less than 1 ohm, which is in the conduction state;

4. Note: Do not measure the resistance between 1 and 2 (there is battery voltage between them), otherwise there will be potential danger!



5.2.7 Dimensions:

Under the test conditions of the standard test environment in 5.1.1, use the test equipment in 5.1.3 (2) to test the battery dimensions.

6. Quality inspection

Quality inspection is used to determine whether the battery pack is qualified to ensure the stability of product quality during the production process, and can refer to GB/T8897.1-2013, GB8897.2-2013 standards for implementation.

7. Packaging labeling

Based on the agreement between the supplier and the buyer, it is packaged according to the prescribed method. Put the packing list and inspection report in the packing box, and the battery pack is affixed with the certificate of conformity, warnings, user records, and the production date will be marked on the tube wall of the battery pack.

8. Precautions

MWD-QDT (150°C) battery pack is produced with unique technology and has certain safety, but as a lithium battery pack, it has certain dangers when it is damaged by electrical function or mechanical function like other battery packs. The MWD-QDT (150°C) battery pack must comply with the following regulations during storage, transportation and use.

8.1 Storage:

MWD-QDT (150°C) battery packs should be stored in a cool, clean and dry environment, the recommended temperature is 10°C-30°C, and the relative humidity is $\leq 50\%$. Avoid contact with corrosive substances, keep away from fire sources and heat sources above 150°C.

Battery storage should strictly abide by the following items:

- ◆ Do not expose the battery to an environment higher than 150°C.
- ◆ Store the battery pack in its original packaging to eliminate any possible external short circuit.
- ◆ Do not store battery packs in conductive antistatic bags or foam.
- ◆ Do not place the battery pack on a conductive metal surface.
- ◆ Do not stack batteries together.

8.2 Transportation:

The battery is in a fully charged state when it leaves the factory. During transportation, it should be packed into a box to prevent severe vibration, impact and extrusion, and prevent the sun and rain. It should be used in ordinary transportation such as cars, trains, ships, and airplanes.

8.3 Safe use:

When using the MWD-QDT (150°C) battery pack, strictly abide by the following regulations to avoid improper operation. This can cause the battery to swell, leak, severely rupture, or even explode.

- ◆ It is strictly forbidden to short circuit between the positive and negative poles of the battery pack, charge and reverse the positive and negative poles;
- ◆ It is strictly forbidden to over-discharge, squeeze, puncture and burn the battery;
- ◆ Do not mix old and new battery packs with other types of battery packs;
- ◆ Do not use the battery in an environment outside the allowable temperature range;
- ◆ Before using the lithium battery pack, you should read the instructions and warnings in detail, operate strictly according to the regulations, and strictly prohibit exceeding the rated indicators;



- ◆ Before the instrument is assembled, the appearance inspection of the battery pack must be done to ensure that there is no damage affecting the performance of the battery pack. There must be no rust, dirt, damage, etc. on the wires and connectors that may cause short circuit or open circuit. Once found, stop using it. And notify professionals to handle it;
- ◆ The protective cap of the plug should be kept properly so that it can be used when the battery pack is temporarily not used or the old battery is recycled for storage and transportation; The use of lithium battery packs should be recorded as a basis for continued use;
- ◆ During the assembly of the lithium battery pack, never short-circuit the two ends of the battery pack. The short circuit of the lead wires and plug contacts of the battery pack may cause the internal fuse to blow. In the event of a battery failure, do not take it lightly;
- ◆ When the batteries are used to the end voltage, they should be taken out of the instrument in time, and returned to the manufacturer's company in batches for disposal.